

Vertical Hammer Replacement..... ©2006 Bill Spurlock

The hammer has a greater affect upon the tone of a piano than any other part we routinely replace. However the full benefits of new hammers are only had if the other action parts are in good condition and well regulated, so the touch and tone are even and controllable. While today we are fortunate to have many quality replacement hammers available, we have fewer options when it comes to other vertical piano action parts. In addition, obsolete designs like brass rails can further complicate action rebuilding in verticals. Therefore it is important to consider the entire piano before launching into a hammer replacement job. The hammer butts are especially important to action performance, so I've included some tips here on refurbishing and replacement of butts.

Many technicians find it easiest to purchase hammers ready to install, while others prefer to bore their own. These instructions will present information on hammer selection, choosing boring dimensions, and installation that should be of value in either case.

Planning the job

Once you've assessed the overall condition of the piano and decided hammer replacement is warranted, you should choose which of two basic approaches to use:

► **Method 1: Pre-hang new hammers on new shanks, then glue these hammer/shank assemblies into the action-** This method is most practical whenever shanks are being replaced, i.e. with new butts or if shanks are removed when the original butts are refurbished. Pre-hung hammers are fast to install because the rake is pre-set. Two or three hammer assemblies can be glued into the action at a time, and need only be aimed straight to the strings and checked for even molding height. This method also allows most hammer spacing to be done by leaning the hammer/shank assembly to one side when gluing into the butt, especially useful with brass rails or horizontal flanges. This method requires a pre-hanging jig (www.spurlocktools.com/id40.htm), discussed on pages 5 & 6.

► **Method 2: Install new hammers on original shanks or on new shank & butt assemblies that are already mounted to the action -** This method is most practical whenever you are reusing the original shanks (i.e. existing butts are in good condition, or original shanks are retained in rebuilt butts).

The choice of method will usually be determined by whether you re-use or replace shanks, and personal preference. Step by step procedures for each method begin on page 5.

Refurbishing or replacement of hammer butts

The condition of the hammer butt is critical to the all-important escapement phase of the keystroke. As the butt leather becomes worn and compressed by the jack top, it's profile changes, causing escapement (jack tripping) to begin earlier in the keystroke, even if letoff is correct. Just as with flat knuckles in a grand, power and control are lost and hammers tend to "bobble." Before deciding to replace hammers, check for worn butt leather, catcher leather, butt felts, pinning, and condition of the wood. It is a waste of time to install new hammers on worn hammer butts—they should be either rebuilt or replaced depending upon the availability of suitable replacements and the work required to rebuild. Options are:

► **Replacing wood flange hammer butts:** There are currently two main options for American pianos, the Pratt-Read and Steinway style butts made in Japan by Tokiwa and sold by several supply houses, and Renner USA's German-made Pratt Read style butts. The Renner parts include Schwander type butt springs built into the flange, saving the work of replacing the existing rail-mounted springs. In either case you may have to modify the hammer rail, as many variations in flange design were used on older pianos. Compare a replacement butt to an original— if you have to choose between maintaining the original centerpin height and maintaining the original butt skin height (where the jack top sits), favor the butt skin height. This will maintain the original capstan & wippen height. Vertical actions will tolerate small changes in butt centerpin location without problem. When in doubt, install new parts on a sample note and check regulation and touch.

► **Replacing brass rail hammer butts:** Replacement brass rail butts by Tokiwa available, but may not match the originals exactly. The biggest problem with brass rails is weakening and breakage with age. If the rail shows any signs of breakage, I suggest converting over to new wood flange Renner or Tokiwa butts. This is usually fairly simple, involving slight trimming of the rail and drilling for flange screws. The brass rail can be used as a drilling template. A single note can be converted for a test. Figure 1 shows a typical conversion.

► **Refurbishing original hammer butts:** If available replacement butts are of poor quality or don't match the originals well, it may be most practical to rebuild the old ones. Assuming the wood is in good condition, replace the butt and catcher leathers, butt felt, bridle strap, spring felt, etc. as needed, and repin flanges. If flanges are bad, consider replacing them with new flanges.

To efficiently replace leathers and felts, remove the spring and hammer rails and damper levers. Then, with the butts still screwed to the action rail, lay them forward. The rail then acts as a holder, allowing you to work on them gang-style. Shave off the butt felts with a chisel, then apply a drop of water/wallpaper remover solution to spots where the leathers are glued. They should remove easily once soaked. Clean up the glue residue; use a hand held piece of hack saw blade in the butt leather groove. New leathers can be glued one end at a time with hot hide glue, or with cyanoacrylate (CA) glue.

If the old shanks are in poor condition, the simple jig at right can be made that allows shanks to be easily drilled out.

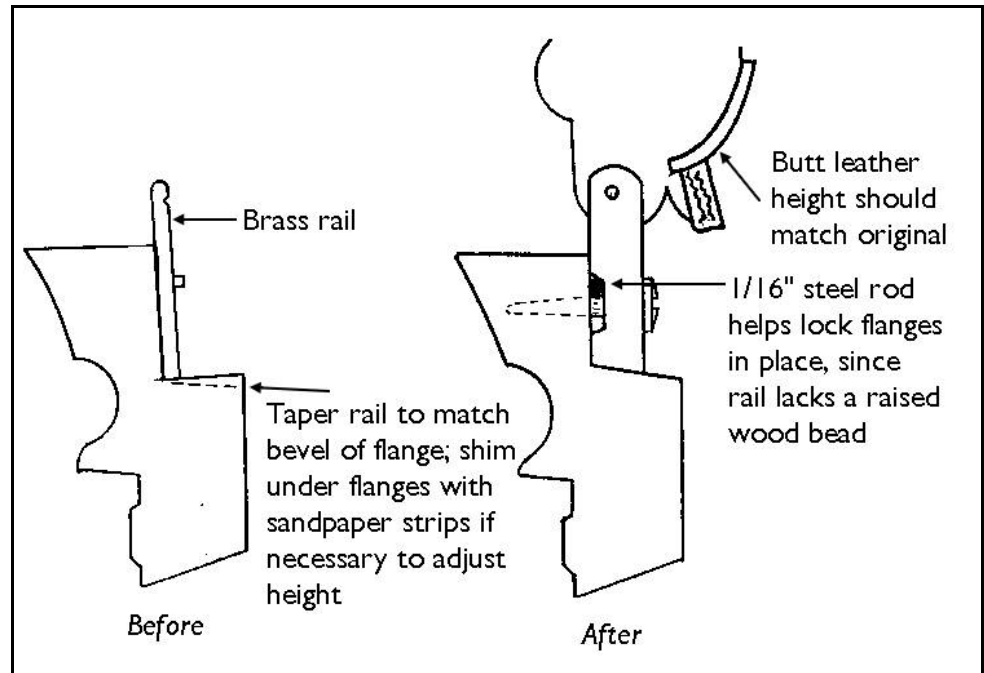

Figure 1: Typical conversion of brass rail to wood flanges

Use a hand held piece of hack saw blade in the butt leather groove.

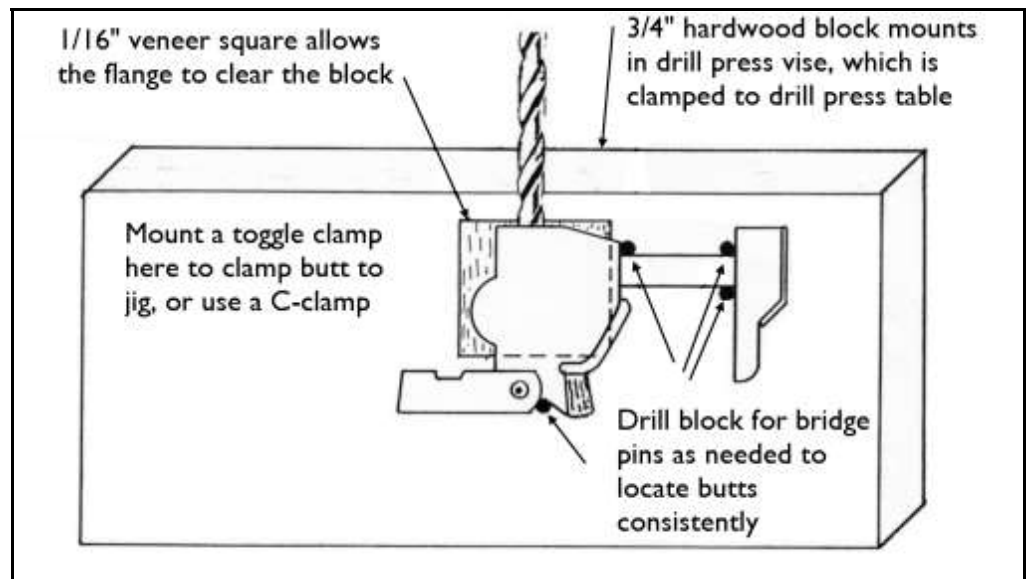

Figure 2: Jig for drilling old shanks out of butts

Selecting new hammers

► **Tone:** You must be able to voice the hammers to a tone that will bring the piano to its potential and satisfy the owner. And, the hammers should maintain their tone for a reasonable period between servicing. One factor here is your own preference for voicing soft hammers up versus bringing harder hammers down. Hammers at either extreme are generally less practical, requiring more work and being less stable.

► **Number of bass/treble:** Many replacement sets come with at least 30 bass and 65 treble hammers, so they accommodate almost any scale.

- ▶ **Length:** the overall hammer length must allow for your chosen bore distance. This is seldom a problem on uprights.
- ▶ **Width:** Replacements should generally match the width of the original hammers. Wider hammers will often cause clearance problems in the tenor and bass.
- ▶ **Size:** Ordinarily replacements should be similar or slightly smaller than the originals (originals have often “ballooned” over the years). Smaller than original bass hammers might allow you to raise the dampers, improving bass damping.

Choosing boring dimensions

Whether you bore your own hammers or order them pre-bored, you need to determine the correct measurements. Here are some guidelines:

- ▶ **Bore distance:** The goal here is to retain the original catcher height and butt skin height. This will maintain the original geometry of the capstan, wippen & jack, damper spoon, and back check. If using the original hammer butts or an exact replacement, copy the original bore distance, estimated from the original hammers (taking wear into account).

Replacement butts may have a very different shank angle, requiring a different bore distance to maintain the original catcher and butt skin heights. To check, mount an old butt with hammer attached and one new butt with bare shank side by side on the hammer rail. Align the tops of the catchers and bottoms of the butt skins of the two butts. If their shanks do not line up, mark the location of the new shank on the side of the old hammer. Measure the new bore distance from the crown of the old hammer to the mark (adding some for estimated wear of the old hammer).

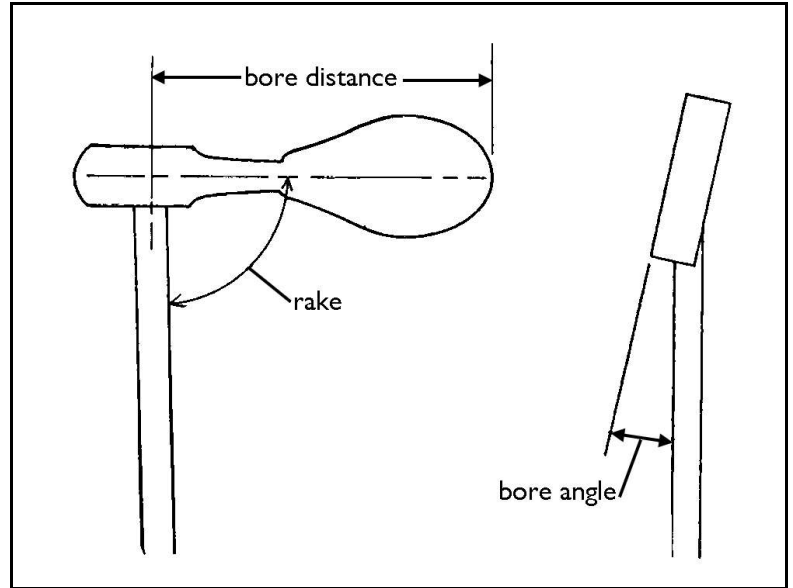

Figure 3: Hammer boring dimensions

- ▶ **Rake:** It is usually assumed the hammer should be 90° to the string at strike position. However some older pianos were built with hammers that over-centered. On quality pianos a conservative approach is to copy the original rake angle unless you see a good reason to change. A small home made square is useful to rest against the strings to check hammer-to-string angle, and to rest against shanks to check the rake of original or new sample hammers.
- ▶ **Bore angle:** The original bore angles in the bass and tenor can usually be duplicated. However, if passing clearance is a problem, bore angle can be reduced slightly. The tenor bore angle can be graduated every few hammers as the strings straighten out.

Preparing hammers for installation

1. Numbering: Upon opening the package, select all excess hammers from the set and push them slightly out of line with the remaining 88. Then, number the 88 to be used, marking the discards with an adjacent number and an "X" (if they are not factory numbered). This way, you will know what number the extras are and can use them as replacements in case you damage one from the set. They can also serve as samples to test on another piano.

2. Pre-filing/needling: If you are familiar with the replacement hammers and know they will need a certain amount of needling or filing, it is usually simpler (and easier on action centers) to do your basic rough voicing and shaping before installing the hammers. The fixture in figure 4 allows you to clamp one section at a time in a vise; they can be needled and filed easily and quickly as though they were one long hammer. Ironing the hammers while still in the fixture gives clean square edges, making it easier to judge alignment when gluing them on.

3. Boring: There are several good hammer boring jigs on the market. The Brooks, Ltd. jig works well and is most economical, while the Renner USA jig is more sophisticated at a higher price. Normally you will use a $7/32$ " bit, then knurl the shanks for a free but close fit. A quality brad point bit run at high rpm will minimize wandering.

4. Taper sides of bass, low tenor, and treble hammers: Tapering the right side of the bass hammer moldings, and the left side of angled tenor hammers, will increase passing clearance. In addition, you may wish to taper both sides of the high treble hammers to reduce mass and improve treble tone, especially on

quality pianos where this was done originally. The simple jig shown below works well with either a belt or disc sander. Use new coarse paper. You need only taper the left side of low tenor hammers and the right side of bass hammers, from the bottom of the felt back. Treble hammers should be tapered equally on both sides, from about the staple on back. For the cleanest and most accurate tapering job, use Hammer Tapering Jig (www.spurlocktools.com/id35.htm).

Record the strike line on the piano strings

Because hammer bore distance and rake are often changed when installing new butts, it is convenient to mark the original strike line on the strings as a point of reference to use when installing the new sample hammers.

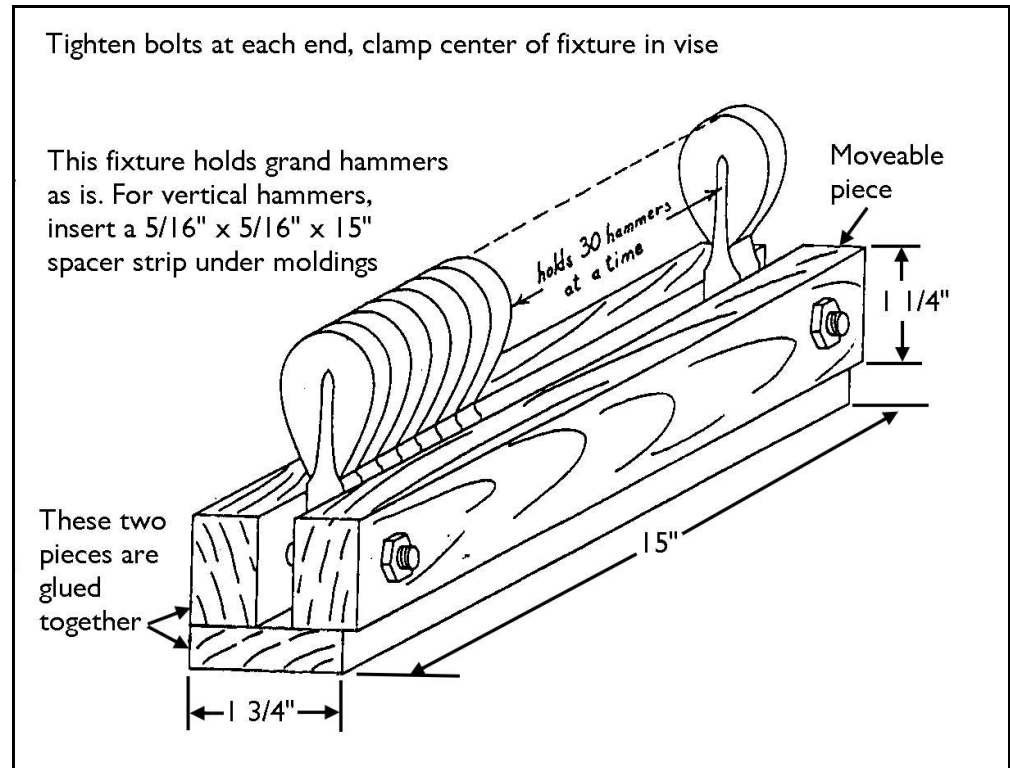

Figure 4: Hammer pre-filing & voicing fixture

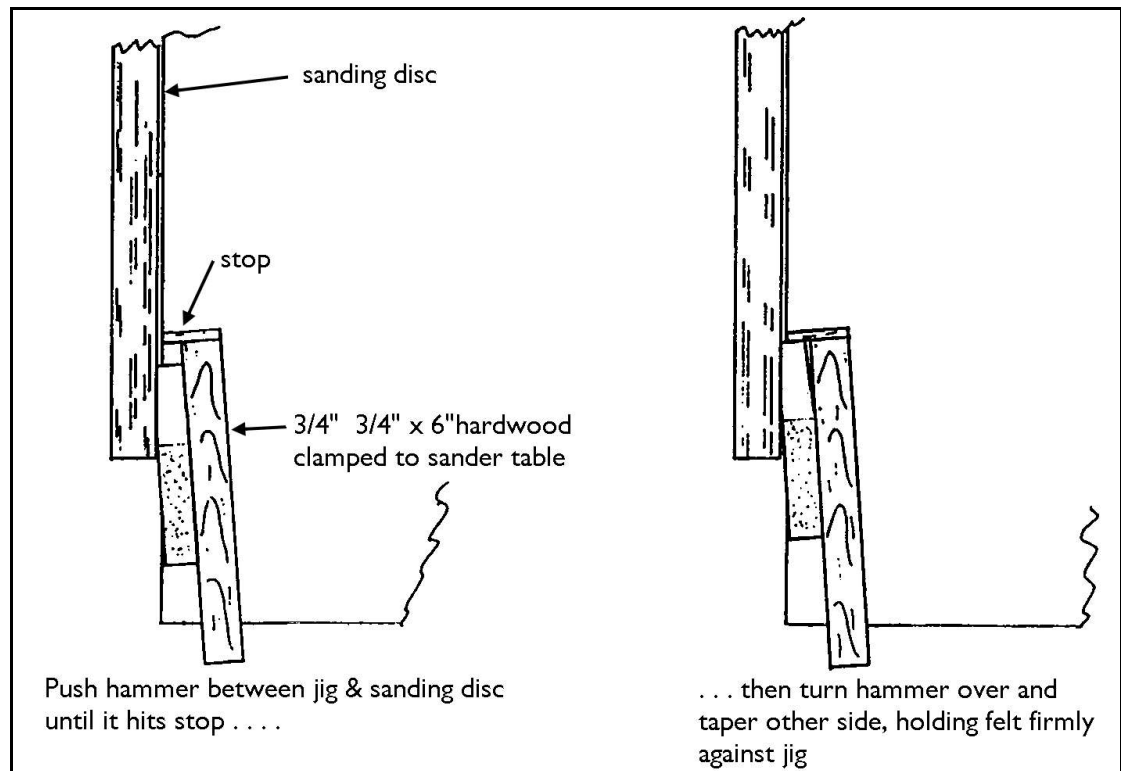

Figure 5: Jig for tapering moldings

Note: Correct any uneven spacing of the unison strings before proceeding.

1. Mark the centerline on each side of original hammer #1 and the first tenor hammer.
2. Lay a line of masking tape across all strings at approximate hammer strike height.
3. Push hammer #1 toward the strings until it is in position where it would be touching the string if it had no wear (estimate original size). See figure 6 below.

4. With the hammer held in this position, sight down the centerline of the hammer and mark the strike point on the masking tape *on each side* of the hammer.

5. Mark the midpoint of the two marks—this will be the location of the strike line at hammer #1.

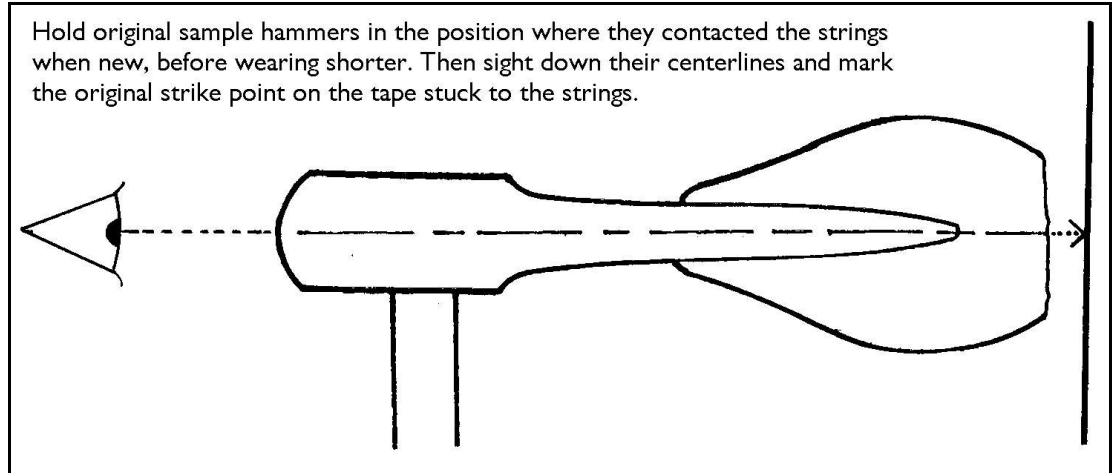

Figure 6: Marking the strike line on tape strip

6. Repeat for the first tenor hammer, and any others if desired.
7. Mark the tape at unison #88, 1/8" below the center of the V-bar.
8. Stretch a thread (thin elastic thread from a fabric store works best) between the #1 and #88 marks, and see if the first tenor mark falls on the line. If not, compromise between the first tenor and #1 marks and make new marks for them.
9. Use a straightedge to draw a strike line from #1 to #88 on the tape. Your new hammers will be installed to strike on this line, regardless of changes in bore distance, pitch, hammer butt design, etc.

Method 1: Pre-hanging new hammers on shanks

Note: The following work is easiest with the hammer rest rail and spring rail removed.

1. Install & travel butts: Install the new butts on the action. When pre-hanging hammers onto loose shanks, you must travel the hammer butts *first*, before gluing the shanked-up hammers into the butts. To do this, insert spare shanks into one section of butts dry, using small paper strips to shim if necessary for a snug fit. Then, check the travel of each shank using a small square against the unison strings (or use a square against the hammer rest rail if not at the piano). Correct traveling as needed using self adhesive paper between flanges and rail, adhesive side toward the flange. Remove the spare shanks. Note: for horizontal flanges such as older Steinways, traveling is adjusted by loosening the flange screw and rotating the flange. Once set, these horizontal flanges must stay secure or travel will change.

2. Prepare shanks: Select 88 shanks, checking for straightness by rolling on a flat surface, and rejecting any with diagonal or other grain problems. Knurl *one* end of each shank—use an adjustable bench knurler to size the shanks uniformly so the hammers fit freely but without wobble. Make a glue escape slot as shown below.

3. Shank up guide hammers (first and last of each section): Mark centerlines on the sides of the new guide hammers. Then, glue a shank into each guide hammer.

4. Trim guide shanks to length: With the action in the piano, fit the guides into their butts, trimming the lower ends of the shanks by trial and error until the centerlines of the guide hammers are about 1/16" below the strike line on the tape when fully

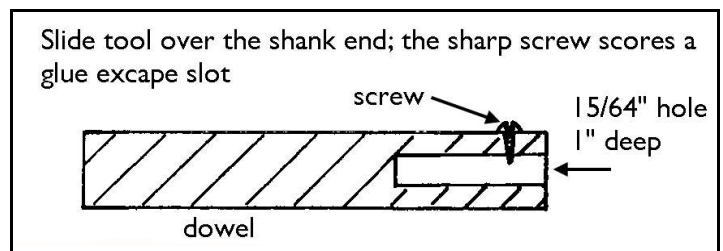

Figure 7: Hammershank glue escape slot maker

seated (glue moisture will cause them to sit slightly higher when actually installed). Note: You may wish to sweep the hammer line upward in the first five or so tenor notes to allow for longer dampers in this area. If so, use the sixth hammer above the break as your sample, trimming its shank so it aligns to the strike line. Then, after shanking up all hammers in that section, trim all tenor shanks to match the samples, except increase the lengths of the lowest five tenor hammer shanks in 1/16" increments; i.e. fifth shank 1/16" longer, fourth shank 1/8" longer, third 3/16", etc.

5. Shank up all hammers using jig: See jig details below. Place the first and last guides of a section into the shanking jig, the correct number of spaces apart. Adjust the jig to the guides, and shank up all hammers of that section. Use hot hide glue or yellow wood glue, making sure to apply glue to *both* the hammer and shank. Then install the shank trimming guide even with the ends of the guide shanks. Using a fine hand saw, cut along the board to trim all shanks of the section to length. Our 10-2410 Japanese pull stroke saw works well for this (www.spurlocktools.com/id37.htm). Repeat for the other sections.

6. Knurl the lower ends of all shanks. Note: at this point the remaining steps can be done with the action on the bench if desired. However working in the piano allows side-to-side spacing during gluing, a major advantage.

7. Check dry fit of shanked up hammers: Install the hammer rest rail on the action, so shanks will lay in a straight line as they are installed. Drop the shanked up hammers of a section into their butts, and double check shank length using a straightedge across the tops of the hammer moldings. Trim shanks on any hammers that sit too high (don't worry if some are slightly low). Also check side-to-side alignment of hammers to unison strings, and bevel the lower ends of shanks if needed to allow them to be leaned (if adequate spacing cannot be done by shifting flanges on the rail, or in the case of a brass rail).

8. Install the shanked up hammers into the action: Glue hammers in place, making sure to apply glue to both butts and shanks. Two or three shanks can be glued in at once, then checked for alignment before proceeding. Check molding height with a straightedge, check that hammers aim straight toward strings, check hammer/unison alignment, and check for even catcher height. The easiest way to check that hammers are aiming straight toward the string plane is by holding a straightedge against the back of the moldings—if the end of a molding is not square to the straightedge, the hammer is aiming off to one side. This test is especially valuable in the angled hammer sections. Check catcher height by laying a hammer shank across the tops of a group of catcher shanks.

The Spurlock Specialty Tools Vertical Hammer Pre-Hanging Jig

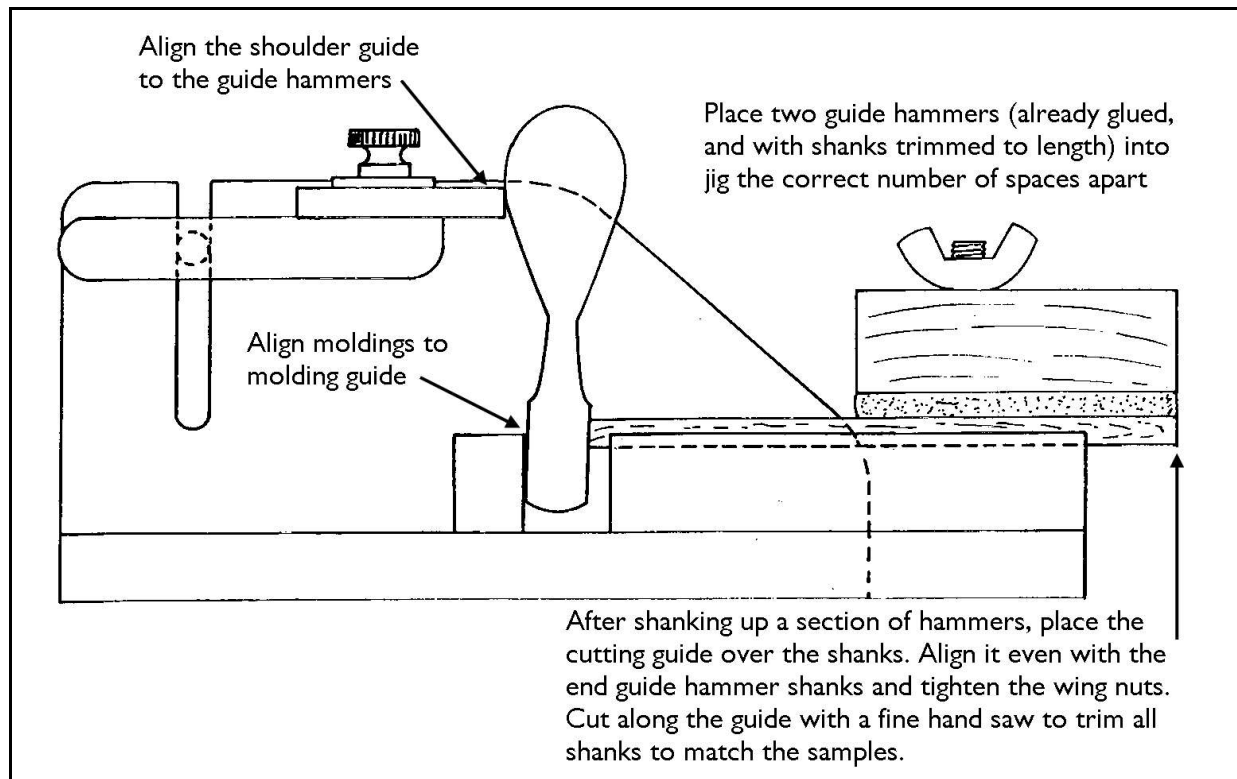

Figure 8: The hammer pre-hanging jig

Method 2: Installing new hammers onto shank/butt assemblies

This method can be used with the action in the piano or on the bench. Either way uses new guide hammers installed near the end of each section. Installing these guides at the correct height is important. Note that as hammers wear shorter, they over-center more and strike at a lower point on the strings. Therefore the strike point marked on the crown of a new guide hammer must be lined up to an imaginary point at the original (unworn) crown of an adjacent original hammer, *not* aligned to a mark on the worn crown of an original hammer. This is especially tricky to do if the new hammers are bored at a different rake. *In that case it is wise to install at least the new guide hammers with the action in the piano, aligning them to a strike line marked on tape as in method 1, even if the others will be installed on the bench.* That way you ensure the height and rake of the new hammers will be correct. (While the action could be raised or lowered to match improperly hung hammers to the strike line, this upsets hammer/string and damper/string alignment in the angled string sections, and could put capstans beyond their range of adjustment.)

1. Install butts

2. **Select, knurl & install shanks (if new shanks are being used):** Glue shanks into butts, visually aligning them parallel.

3. Travel shanks

4. **Install guide hammers:** In the piano - similar to step 3&4 for method 1. On the bench - mark the center of the crowns on the new guide hammers and the original guide hammers (usually first and last of each section). Dry fit the new guides adjacent to the old guides, trimming the shanks if necessary until the strike points of the new guides line up with the (estimated) original unworn guide strike points.

5. **Trim all remaining shanks to match new guide shanks, if necessary, & make glue escape slots**

6. **Glue the new guides on, and remove all original guides**

7. **Install remaining new hammers:** Glue two or three at a time, using a straightedge between guides to check molding height, hammer shoulder height, and that hammers aim straight to the strings.

Our Grand Hammer Hanging Jig (www.spurlocktools.com/id33.htm) also works well here—just remove the hammer rail, lay the action back almost horizontal using action cradles, and adjust the jig to the guide hammers as shown in figure 9 below. Be sure that the lower deck of the jig is parallel to the main action rail—that way vertical alignment of the hammers can be judged by looking for parallel mating between the ends of the moldings and the lower deck.

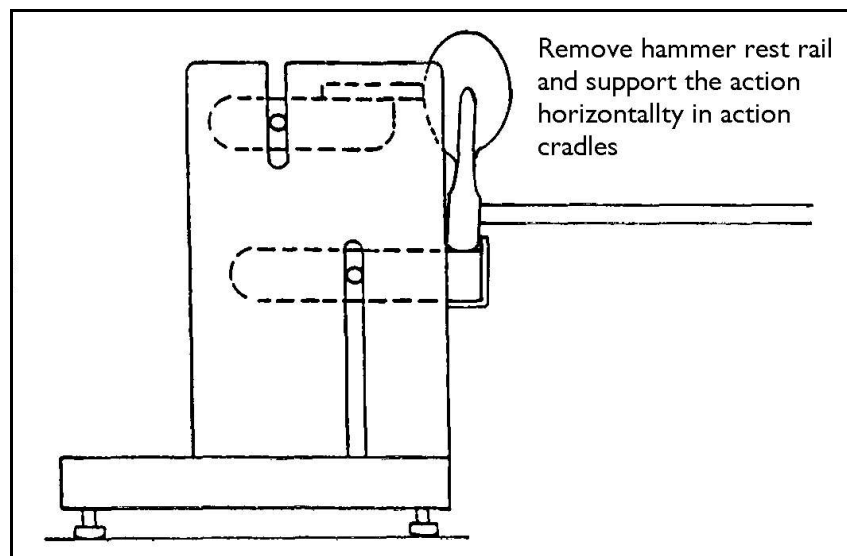

Figure 9: Using the Spurlock Specialty Tools Grand Hammer Hanging Jig for vertical hammer installation

You can see all of our products at: www.spurlocktools.com